

517 KEEPHILLS/ELLERSLIE/GENESEE (KEG) AREA OPERATION

1. Purpose

To define the interim policies and procedures applicable for the 2010 Keephills 3 system and the Edmonton region 240kV transmission line upgrades project.

~~To provide policies and procedures on the operation of the KEG area to ensure reliable operation of the area.~~

2. Background

(1) The “KEG area cut plane” means and consists of the Keephills 240/138kv transformer and all transmission lines connecting the Keephills and Genesee substations to the interconnected electric system. The KEG area transmission system is illustrated in Figure 1.

(2) The KEG area transmission system will be the subject of a major construction project in 2010 with the addition of Keephills #3, the decommissioning of Wabamun #4, and an upgrade to the transmission system extending from the Lake Wabamun area to south Edmonton. The overall project includes a new phase shifting transformer and another 240kV transmission line terminated at Keephills. 1202L which currently operates at 240kV will be operated at 500kV.

(3) For the duration of this project, a significant number of expedited changes to the KEG area operating procedures are required and will be identified in the System Coordination Plan throughout the duration of the project. The schedule for the project phases is available to market participants on the AESO website <http://www.aeso.ca/transmission/20222.html>.

(4) Specifically, as the KEG area transmission system reinforcements proceed, the ISO must implement a number of transient generation curtailments related to the various transmission line outages. In addition, when 1203L or 1209L is out of service, the total generation output from the Genesee plant is transmitted on the sole remaining 500 kV line connecting the Genesee plant. This significantly increases the most severe single contingency level on the interconnected electric system. The ISO therefore must issue directives to ensure the continued reliable interconnected electric system operations, which limits may include limiting import levels and Genesee total plant output.

(5) Other area 240 kV transmission line contingencies also may require reliability directives to ensure that the system can meet reliability criteria. Delayed fault clearing on any of the 240 kV transmission lines connected to the KEG area and Sundance generating plants may cause angular instability to the area generators. Refer to Section 3.3(2) for a list of these transmission lines.

(6) Throughout the project schedule, the operation of the KEG area transmission system must meet WECC reliability criteria, which is summarized in the following two categories:

(a) The interconnected electric system must be able to continue to operate safely and efficiently, even with the immediate effects of the contingencies; and

(b) That system must be able to recover from the contingencies and prepare for the next contingency in a timely fashion that meets WECC standard requirements.

OPP 517 Keephills/Ellerslie/Genesee (KEG) Area Operation

The KEG area transmission system is illustrated in Figure 1. Within the KEG area, the KEG loop consists of the following transmission lines:

- 1203L 500 kV connecting the Genesee plant substation E330P and the Keephills plant substation T320P
- 1209L 500 kV connecting the Genesee plant substation E330P and the Ellerslie substation T89S
- 1202L 240 kV connecting the Keephills plant substation T320P and the Ellerslie substation T89S.

There are two other 240 kV transmission lines, 903L and 190L, which connect the Keephills plant substation T320P and the Benalto substation (T17S). One 138 kV line, 834L, connects the Keephills plant substation T320P and the Keystone substation (T384S).

When 1203L or 1209L is out of service, the total generation from the Genesee plant is transmitted on the remaining 500 kV line connecting the Genesee plant. This increases the single largest contingency (SLC) level in the AIES. Operating limits to ensure reliable system operation with this increased SLC need to be applied.

Other area 240 kV line contingencies in the area also require remedial actions to ensure that the system can meet reliability criteria. Delayed fault clearing on any of the 240 kV lines connected to the KEG area and Sundance generating plants could potentially cause angular instability to the area generators (see Section 3.1 for details).

The operation of the KEG area must meet WECC reliability criteria, which can be summarized into the following two categories:

- The system must be able to sustain the immediate effects of the contingency.
- The system must be able to recover from the contingency and prepare for the next contingency in a timely fashion that meets WECC balancing authority requirements.

3. Interim Operating Policy during 2010/2011 Project

3.1 **Delayed fault clearing** KEG cut plane

(1) The determination of the KEG cut plane and the calculation of the KEG cut plane total outflows will change as the project progresses and the grid interconnected electric system in the KEG area evolves from its current state to the final state when the project is completed. The KEG cut plane outflows will be defined as the totalized outflows on the 240 kV and 500 kV lines connecting the Keephills (T320P) and Genesee (E330P) substations to the Alberta Interconnected eElectric sSystem (AIES). KEG cut plane flow is defined as the sum of the following outflows in MW:

- (a) Outflow on 1209L measured at the Genesee plant substation E330P,
- (b) Outflow on 1202L measured at the Keephills plant substation T320P,
- (c) Outflow on 190L measured at the Keephills plant substation T320P,
- (d) Outflow on 903L measured at the Keephills plant substation T320P, and
- (e) Outflow on Keephills T320P T1 measured at the Keephills plant substation T320P.

(2) For the purposes of calculating the sum of the flow under subsection 1, it will be deemed to be zero (0) if the flow is towards the measured point.

OPP 517 Keephills/Ellerslie/Genesee (KEG) Area Operation

Delayed fault clearing on any of the 240/500 kV transmission lines terminated at the Keephills plant substation (T320P), the Genesee plant substation (E330P) or the Sundance plant substation (T310P), could potentially result in angular instability to the area generators. These lines include 190L, 902L, 903L, 908L, 909L, 913L, 919L, 922L, 926L, 973L, 974L, 989L, 1202L, 1203L and 1209L.

Examples of delayed fault clearing conditions include the simultaneous A and B protection failures or loss of the protection telecommunication, stuck breaker and other conditions that would extend the breaker operation time.

The transmission facility operator must immediately notify the SC of any known risk of delayed fault clearing on any of the above mentioned lines, and take urgent actions to rectify the problem.

Upon notification by the transmission facility operator on potential delayed fault clearing on any of the above mentioned lines, the AESO will make a real time assessment, taking in consideration of the current and expected operating conditions, and may direct the curtailment of area generation and/or removal of the affected line or equipment.

3.2 KEG cut plane System Normal

(1) Under normal system conditions the KEG cutplane (see Figure 1) will be constrained to specific limits. As these limits are subject to change through this project, the limit as it changes from time to time will be displayed on the AESO website: <http://www.aeso.ca/transmission/20222.html>. KEG cut plane flow is defined as the sum of the following outflows in MW:

- Outflow on 1209L measured at the Genesee plant substation E330P;
- Outflow on 1202L measured at the Keephills plant substation T320P;
- Outflow on 190L measured at the Keephills plant substation T320P;
- Outflow on 903L measured at the Keephills plant substation T320P, and
- Outflow on Keephills T320P T1 measured at the Keephills plant substation T320P.

Note: If power flows towards the measured point, it is considered as zero

3.3 Normal system conditions at the KEG area Allowable Most Severe Single Contingency at Genesee

(1) With respect to the KEG area transmission system, during the 2010 project period of system upgrading, reinforcement and construction, the ISO system controller will operate the interconnected electric system within prescribed limits determined by engineering studies, and will take any requisite immediate action to reduce the most severe single contingency to acceptable levels.

(2) Specifically, if the Genesee generating facilities are connected to the interconnected electric system by a radial feed when 1203L or 1209L are out of service; then the MW output of the Genesee generating facilities, consisting of the net to grid energy and dispatched operating reserve for GN1, GN2, and GN3, will become the interconnected electric system's most severe single contingency.

(3) Therefore, the maximum allowable most severe single contingency for Genesee generating facilities is:

Transmission

OPP 517 Keephills/Ellerslie/Genesee (KEG) Area Operation

(a) 1,000 MW if the Alberta-BC interconnection import ATC is not constrained as per OPP 304 (zero import assumed); or

(b) 450 MW if the Alberta-BC interconnection import ATC is constrained by transmission element outages as identified in Table 2 of OPP 304.

(4) The sum of the net to grid output and dispatched operating reserves from the Genesee generating facilities by directive will be constrained to the maximum allowable most severe single contingency level.

(5) With respect to the most severe single contingency for Genesee, the NWPP reserve sharing (refer to OPP 405) will be used by the ISO system controller for the portion of the reserve requirement exceeding the Alberta contingency reserve obligation. To reserve capacity on the Alberta-BC interconnection for the delivery of the NWPP reserve sharing energy, the Alberta-BC interconnection import ATC will be reduced.

(6) To facilitate the reduction in import ATC referred to in Subsection 3(a) above, a variable import TRM will be used, and will be a quantity in MW calculated as follows:

Import TRM equals:

Import TTC as per OPP 304 MINUS the import ATC (see Table 3)

(7) Notwithstanding any other provision of this OPP 517, if the available NWPP reserve sharing to Alberta is insufficient to support the most severe single contingency at the Genesee generating facilities, then the most severe single contingency at Genesee will be reduced accordingly.

~~Under normal system conditions at the KEG area and high Edmonton area load (equal or greater than 1850 MW and below 1900 MW), the KEG cut plan will be constrained as follows for preparing the next contingency of 1209L:~~

- ~~• Depending on status of Clover Bar units, the KEG cut plane flow will be constrained as specified in Table 1.~~
- ~~• Depending on the status of Clover Bar and Sundance units, the KEG cut plane flow will be constrained as specified in Table 2.~~

3.4 ~~1209L out of service~~ Generating Facilities Curtailments

(1) As transmission system elements are removed from service to facilitate the various construction and upgrade configurations, the ISO system controller by directive and as necessary will curtail the output of generating facilities situated in the KEG area transmission system, but only as required to ensure the most severe single contingency limits will keep the interconnected electric system operating in a safe and reliable state.

(2) If the system controller is required to curtail the sum in MW of the outputs of two or more generating facilities to specified levels, then the curtailments must be calculated and implemented on a pro-rata basis, based on the STS level of each of the generating facilities.

(3) No generating unit which is the subject of a curtailment directive will be curtailed to a level below its minimum stable generation if another generating unit in the KEG area subject to such a directive can be curtailed to meet the limit.

(4) For any generating facilities, the system controller will first curtail net to grid energy, followed by the dispatched operating reserves.

OPP 517 Keephills/Ellerslie/Genesee (KEG) Area Operation

(5) Any generating facilities receiving a directive to curtail under this OPP 517 must have responded and complied with the directive to reduce output to the required limits, no later than 40 minutes after the time of receipt of the directive.

(6) The ISO must prepare, publish and keep timely a System Coordination Plan for the KEG area which sets out:

(a) any and all known or reasonably anticipated MW curtailments or restorations to generating facilities output, transmission line outages, and Alberta-BC interconnection import limits which are required during the 2010 period of upgrading, construction and reinforcement.

(b) any additional operational information as is reasonably necessary for directly impacted market participants to further understand the objectives, timing and scheduling relating to the 2010 project.

~~Remedial actions required when 1209L is out of service are summarized in Table 3. The most constraining of the following factors will be applied:~~

~~□ The next contingency of 1203L will cause the loss of the Genesee plant. Therefore, the Genesee plant generation can potentially become the SLC in the AIES. See Section 3.12 for more information.~~

~~□ The next contingency of 1202L will cause the Genesee and Keephills generation to be transmitted entirely on 903L, 190L and Keephills T320P-T1 causing severe overload on these lines and transformer. To address these concerns, the KEG cut plane flow is limited to 1,240 MW in summer and 1,300 MW in winter respectively.~~

3.5 ~~1203L out of service~~ Delayed Fault Clearing

(1) The removal of a faulted transmission line from service is required of a transmission facility owner (based on studies) to provide for increased interconnected electric system reliability and stability.

(2) Delayed fault clearing on any of the 240/500 kV transmission lines terminated at the Keephills substation (T320P), the Genesee substation (E330P) or the Sundance substation (T310P), could potentially result in angular instability to the area generators. These lines include 190L, 902L, 903L, 908L, 909L, 913L, 919L, 922L, 926L, 973L, 974L, 989L, 1202L, 1203L and 1209L or 1043L, 1044L and 1045L as renumbered lines replacing 904L and 908L.

(3) The transmission facility operator of any of the specific transmission lines referred to in subsection 3.3 (2) above must immediately notify the ISO system controller of any known risk of delayed fault clearing on the subject transmission line, and take immediate action to rectify the problem.

(4) Upon notification by the transmission facility operator on potential delayed fault clearing on any of the transmission lines, the system controller will make a real time assessment, taking into consideration the current and expected operating conditions, and may issue directives for the curtailment of area generation or require the removal of the affected transmission line or equipment, or any or all such actions.~~Remedial actions required when 1203L is out of service are summarized in Table 3.~~

~~□ The next contingency of 1209L will cause the loss of the Genesee plant. Therefore, the Genesee plant generation can potentially become the SLC in the AIES. See Section 3.12 for more information.~~

~~3.6—1202L out of service~~

Transmission

OPP 517 Keephills/Ellerslie/Genesee (KEG) Area Operation

~~□ The next contingency of 1209L will cause the Genesee and Keephills generation to be transmitted entirely on 903L, 190L and Keephills T320P T1 causing severe overloads on these lines and the transformer. To address these concerns, the KEG cut plane flow is limited to 1,240 MW in summer and 1,300 MW in winter respectively.~~

~~□ Remedial actions required when 1202L is out of service are summarized in Table 3.~~

~~3.7 190L out of service~~

~~Remedial actions required when 190L is out of service are summarized in Table 3. The most constraining of the following factors will be applied:~~

~~□ The next contingency to 1209L may cause overload to the remaining 903L, and to a lesser extent, to 1202L. To prepare for these contingencies, the KEG cut plane flow is limited to 1,620 MW in summer and 1,750 MW in winter respectively if all Keephills units are in service.~~

~~□ If either Keephills # 1 or Keephills # 2 is offline, the KEG cut plane flow is limited to 1,500 MW both in summer and winter.~~

~~3.8 903L out of service~~

~~Remedial actions required when 903L is out of service are summarized in Table 3. The most constraining of the following factors will be applied:~~

~~□ The next contingency to 1209L may cause overload to the remaining 190L, and to a lesser extent, to 1202L. To prepare for these contingencies, the KEG cut plane flow is limited to 1,660 MW in summer and 1,750 MW respectively if all Keephills units are in service.~~

~~□ If either Keephills # 1 or Keephills # 2 is offline, the KEG cut plane flow is limited to 1,500 MW both in summer and winter.~~

~~3.9 Keephills T320P Transformer # 1 out of service~~

~~If Keephills T320P T1 is out of service, the KEG cut plane is limited to 1,910 MW both in summer and winter.~~

~~3.10 Allowable single largest contingency at Genesee~~

~~This section applies when either 1203L or 1209L is out of service and the generation of the Genesee plant is transmitted over one transmission line.~~

~~□ The SLC at Genesee is the sum of the total net generation and dispatched operating reserve of the generating units at the Genesee plant.~~

~~□ If the Alberta-BC interconnection import available transfer capability (ATC) is not constrained as per OPP 304, the sum of the SLC at Genesee and Alberta-BC interconnection must not be greater than 1000 MW.~~

~~□ As summarized in Table 4, the maximum allowable SLC at Genesee is:~~

~~□ 1,000 MW if the Alberta-BC interconnection import ATC is not constrained as per OPP 304. (zero import assumed)~~

~~□ 450 MW if the Alberta-BC interconnection import ATC is constrained by transmission element outages as identified in Table 3 of OPP 304.~~

~~□ The sum of the net generation and dispatched operating reserves from the Genesee plant generating units will be constrained to the maximum allowable SLC level.~~

~~□ The Alberta-BC interconnection import ATC is affected by the magnitude of the SLC at Genesee as shown in Table 5.~~

Transmission

OPP 517 Keephills/Ellerslie/Genesee (KEG) Area Operation

~~□ The NWPP reserve sharing will be used for the portion of the reserve requirement exceeding the Alberta contingency reserve obligation (CRO). To reserve capacity on the Alberta-BC interconnection for the delivery of the NWPP reserve sharing energy, the Alberta-BC interconnection import ATC will be reduced.~~

~~□ To facilitate the reduction in import ATC, a variable import transmission reliability margin (TRM) will be used:~~

~~— Import TRM = Import TTC (as per OPP 304) minus the import ATC (as per Table 3)~~

~~□ If the available NWPP reserve sharing to Alberta is insufficient to support the SLC at Genesee, the SLC at Genesee will be reduced accordingly.~~

3.11 Generation curtailments

~~□ In a circumstance when the SC has to constrain the sum of the generation outputs of two or more generators in the KEG area to a specified level, the curtailment level of each of the generators will be determined by the SC pro-rata based on the STS level of each generator.~~

~~□ Notwithstanding the immediately foregoing bullet, a generator will not be curtailed to a level below its minimum stable generation (MSG) if any other generator in the KEG area may be curtailed to meet the particular limit. The MSG levels for generators in the KEG area are listed in confidential Table 8.~~

~~□ Energy is curtailed first and then the dispatched operating reserve services.~~

~~□ A real time tool has been developed for use by the SC to determine the required generation curtailment to area generators.~~

~~□ As a fail-safe measure, if the real time tool is unavailable for use for the SC, the SC will use the curtailment levels as calculated based on each area generator generating at its MCR level. The curtailment levels are shown in Table 6.~~

~~□ Generation at the KEG area must be curtailed to the required limits within 40 minutes of receiving a directive from the SC.~~

3.12 After an SLC event at Genesee

~~□ The NWPP Contingency Reserve sharing procedures will be implemented to request the required contingency reserve amount exceeding the Alberta CRO. For details, refer to OPP 405.~~

~~□ ILRAS will be armed according to the scheduled import level, inclusive of the NWPP reserve energy flow, as described in OPP 312.~~

~~□ As energy is dispatched in the energy market, the priority will be to reduce the amount of the NWPP reserve request to zero.~~

~~□ As energy is further dispatched in the energy market, the directive amount for the Alberta contingency reserve will be reduced to zero.~~

~~□ The Alberta-BC interconnection import ATC and import TRM will revert to the normal (non-SLC constrained) value as described in OPP 304.~~

3.13 Lines and transformers energization at the KEG area

~~To prevent overvoltage and undervoltage problems, the following energization procedures will be applied:~~

~~□ T320P Keephills 500/240 kV transformer T6 should be energized from the 500 kV side. If it is impossible to energize it from the 500 kV, energize from the 240 kV side only when all 240 kV lines (that is 1202L, 903L and 190L) into T320P Keephills are in service.~~

OPP 517 Keephills/Ellerslie/Genesee (KEG) Area Operation

- ~~□ 1203L can be energized from either T320P Keephills or E330P Genesee.~~
- ~~□ 1209L must be energized from T89S Ellerslie.~~
- ~~□ T89S Ellerslie 500/240 kV transformers T1 and T2 must be energized from the 240 kV side.~~

~~3.14 Voltage management at the KEG area~~

~~When 1209L or 1202L is out of service, the 240 kV bus voltages at the Ellerslie substation (T89S) and the East Edmonton substation (T39S) must be maintained above 246 kV and 244 kV respectively. Mitigation measures to maintain the above specified voltage levels is described in [Section 5.9](#).~~

4. Responsibilities

4.1 ISO

~~The ISO will:~~

- ~~• Outline in the System Coordination Plan any additional requirements or deviations to this OPP for generation dispatch or Alberta-BC interconnection import limits. The System Coordination Plan will outline any additional operational information necessary for operation under maintenance outage conditions.~~
- ~~• Review and update this OPP as transmission facilities, loads and generators in the KEG area are modified, and issue updated versions of this OPP.~~

~~**System Controller**~~

~~The SC system controller will must:~~

~~(1) Call the real-time operations manager for assistance upon notification by the transmission facility operator of potential delayed fault clearing on the following lines: 190L, 902L, 903L, 908L, 909L, 913L, 919L, 922L, 926L, 973L, 974L, 989L, 1202L, 1203L and 1209L or 1043L, 1044L and 1045L as renumbered lines replacing 904L and 908L;~~

- ~~• Upon notification by the transmission facility operator on potential delayed fault clearing on the lines identified in [Section 3.1](#), call the Operations on call staff for assistance. Direct any mitigation plan as recommended.~~

~~(2) Issue directives for any mitigation plan as recommended;~~

- ~~• Direct curtailment of Genesee and Keephills generation outputs under various area 240 kV line contingencies as set out in this OPP.~~

~~(3) Issue directives requiring any curtailments referred to in this OPP 517 for each phase of the project;~~

- ~~• Adjust and implement the import TTC, TRM and ATC on the Alberta-BC interconnection as required by this OPP.~~

~~(4) Adjust and implement the import TTC, TRM and ATC on the Alberta-BC interconnection in accordance with this OPP 517;~~

~~(5) Inform the BCTC operator when Alberta most severe single contingency SL exceeds 450 MW.~~

~~(6) Determine the need for and initiate NWPP contingency reserve requests; and ERC requests as set out in this OPP and in [OPP 405](#).~~

OPP 517 Keephills/Ellerslie/Genesee (KEG) Area Operation

~~(7) Coordinate with all transmission facility owners when TFOs for energizing transmission lines and transformers at in the KEG ~~area in accordance with Section 3.12.~~~~

4.2 Generation Facility Operators

~~Generation facility operators will:~~

~~Comply with SC directives on generation curtailment.~~

~~Upon receiving the SC directive on generation curtailment, take immediate steps to decrease generation to the level as directed within 40 minutes.~~

~~Notify the SC immediately if, due to plant operating conditions, the SC directive can not be complied with, and provide details.~~

~~4.3—British Columbia Transmission Corporation (BCTC)~~

~~BCTC Operator will:~~

~~Post the updated Alberta-BC interconnection import TTC, TRM and ATC on the BCTC OASIS node immediately upon notification by the SC, and ensure that this information is transmitted to the Vancouver Reliability Coordinator.~~

~~Notify the SC immediately if there is any constraint in the BCTC area that will limit the delivery of the NWPP reserve sharing energy from transmitting to Alberta.~~

4.4—Transmission Facility Operators

KEG area transmission facility operators ~~will~~must:

(1) Investigate any force outage to 1202L, 1203L, 1209L, 190L, 903L or 320P T1 and inform the system controller SC of the status of the affected line or transformer;

(2) Immediately inform the system controller SC of any potential delayed fault clearing on any of the following lines: 190L, 902L, 903L, 908L, 909L, 913L, 919L, 922L, 926L, 973L, 974L, 989L, 1202L, 1203L and 1209L, or 1043L, 1044L and 1045L as newly numbered lines replacing 904L and 908L, and take immediate action to rectify the problem. Inform the system controller when the problem has been resolved; 240/500 kV lines mentioned in Section 3.1 and take **urgent** actions to rectify the problem. Inform the SC when the problem is fixed. and

(3) Consult with the system controller before energizing the following transmission lines and transformers in the KEG area:

(a) T320P Keephills 500/240 kV transformer T6;

(b) Lines energized at 500 kV, presently 1203L and 1209L and 1202L when operating at 500kV;

(c) T89S Ellerslie 500/240 kV transformers T1 and T2. ~~Check with the SC before energizing those transmission lines and transformers as described in Section 3.12.~~

~~• —Energize transmission lines and transformers at the KEG area in accordance with Section 3.12.~~

5. Procedures

None specified.

6. ~~System Controller Procedures~~ Figures and Tables

~~5.1 Delayed fault clearing~~

~~Upon notification by the transmission facility operator on potential delayed fault clearing on any of the lines as identified in Section 3.1, the SC will:~~

- ~~1. Verify with the transmission facility operator that urgent actions are being taken to rectify the problem and request to be updated with the progress.~~
- ~~2. Initiate a call immediately to the Operations on-call person to inform him/her of the situation and that a real time assessment is required to be performed by the Operations Coordination personnel.~~
- ~~3. Upon the conclusion of the real time assessment, direct the mitigation plan which may include the curtailment of area generation and/or removal of the affected line or equipment.~~
- ~~4. Upon notification by the transmission facility operator that the problem has been fixed, cancel the directive(s) issued in step 3.~~

~~5.2 Normal system conditions at the KEG area~~

~~If the KEG area cut plane flow exceeds the limits specified in Table 1 and Table 2, the SC will:~~

- ~~1. Use the real time curtailment tool to determine the required curtailments to the area generators. Issue directives to the Genesee and Keephills plant operators for the curtailments.~~
- ~~2. Dispatch energy in the energy market merit order as required to maintaining AIES supply and demand balance.~~
- ~~3. Initiate Operations callout (see confidential OPP 1303) for unplanned security directives.~~
- ~~4. When the KEG area cut plane flow resumes within limits, cancel the directives for generation and reserve services curtailment to the Genesee and Keephills generators.~~
- ~~5. Enter in the shift log (see OPP 1301) details of all security directives for generation curtailment and restoration including times, generator names and curtailment/ restoration volumes.~~

~~5.3 1209L out of service~~

~~If 1209L is out of service, the SC will:~~

- ~~1. If 1209L was forced out of service, contact the AltaLink Transmission Operator and the EPCOR Transmission Operator to determine the status of 1209L.~~
- ~~2. If the outage to 1209L is anticipated to be more than 20 minutes, proceed with the following procedures. Otherwise, maintain close communication with the AltaLink Transmission Operator and the EPCOR Transmission Operator to get update on the status of 1209L and re-evaluate the need to proceed with the curtailment procedure as required.~~
- ~~3. Contact and notify the Vancouver Reliability Coordinator that the AIES is experiencing abnormal operating conditions that could cause reliability concerns for the AIES.~~
- ~~4. Use the real time curtailment tool to determine the required curtailments to the area generators. Issue directives to the Genesee and Keephills plant operators for the curtailments.~~

Transmission

OPP 517 Keephills/Ellerslie/Genesee (KEG) Area Operation

5. ~~If the real time curtailment tool is unavailable:~~
 - a. ~~Use Table 6 to determine the directive levels to the KEG generators;~~
 - b. ~~Determine the available NWPP reserve sharing to Alberta as displayed on the Ranger Vancouver Reliability Coordinator display.~~
 - c. ~~Verify if:~~
 - ~~Available NWPP reserve sharing to Alberta \geq Genesee SLC – Alberta CRO~~
 - d. ~~If **not**, then reduce Genesee SLC to:~~
 - ~~Genesee SLC = Available NWPP reserve sharing + Alberta CRO~~
 - ~~Pro-rata the Genesee SLC among the online Genesee generators based on STS levels as indicated in Table 7 (confidential).~~
 - e. ~~Issue directives to the Genesee and Keephills plant operators for the curtailments.~~
6. ~~Determine from Table 5 the allowable Alberta-BC interconnection import ATC corresponding to the volume of the SLC at Genesee and:~~
 - a. ~~Re-post the Alberta-BC interconnection import ATC on the AESO website; enter the reason for change as “AIES transmission system constraints”.~~
 - b. ~~Determine the Alberta-BC interconnection import TRM by:~~
 - ~~Import TRM = Import TTC (per OPP 304) – Import ATC~~
 - c. ~~Call and notify the BCTC Operator to change the Alberta-BC interconnection import TRM, TTC and ATC; confirm that these will be posted on the OASIS node immediately. Notify the BCTC Operator that Alberta is having a SLC greater than 450 MW.~~
 - d. ~~Curtail current Alberta-BC import transactions to the allowable import ATC amount if required.~~
7. ~~If 1209L was forced out of service, issue ancillary service directives to the dispatched supplemental and spinning reserves as required. Note that the reserves must be recovered within an hour.~~
8. ~~Dispatch energy in the energy market merit order as required to maintain AIES supply and demand balance.~~
9. ~~If the AIES experiences a supply shortfall, follow the procedures in OPP 801.~~
10. ~~Initiate Operations callout (see OPP 1303) for unplanned security directives if not already done so in step 9.~~
11. ~~Contact and notify the Vancouver Reliability Coordinator that the AIES is back within reliable operating limits when the required generation levels are achieved.~~
12. ~~Coordinate the restoration of 1209L with the AltaLink and EPCOR Transmission Operators.~~
13. ~~When 1209L has been restored:~~
 - a. ~~Cancel the directives for generation and reserve service curtailment to the Genesee and Keephills generators.~~

OPP 517 Keephills/Ellerslie/Genesee (KEG) Area Operation

- ~~b. Contact and notify the BCTC Operator to change the Alberta-BC interconnection import TRM, TTC and ATC as per OPP 304. Notify the BCTC Operator that Alberta is back to normal SLC level.~~
- ~~e. Re-post the Alberta-BC interconnection import ATC, as per OPP 304, on the AESO website.~~
- ~~d. Re-load Alberta-BC interconnection import transactions as appropriate.~~
- ~~14. Enter in the shift log (see OPP 1301) details of all security directives for generation and import curtailment and restoration including times, generator names and curtailment/restoration volumes.~~

5.4 ~~1203L out of service~~

~~If 1203L is out of service, the SC will:~~

- ~~1. If 1203L was forced out of service, contact the AltaLink Transmission Operator and the EPCOR Transmission Operator to determine the status of 1203L.~~
- ~~2. If the outage to 1203L is anticipated to be more than 20 minutes, proceed with the curtailment procedure. Otherwise, maintain close communication with the AltaLink Transmission Operator and the EPCOR Transmission Operator to get update on the status of 1203L and re-evaluate the need to proceed with the curtailment procedure as required.~~
- ~~3. Contact and notify the Vancouver Reliability Coordinator that the AIES is experiencing abnormal operating conditions that could cause reliability concerns for the AIES.~~
- ~~4. Use the real time curtailment tool to determine the required curtailments to the area generators. Issue directives to the Genesee and Keephills plant operators for the curtailments.~~
- ~~5. If the real time curtailment tool is unavailable:~~
 - ~~a. Use Table 6 to determine the directive levels to the KEG generators;~~
 - ~~b. Determine the available NWPP reserve sharing to Alberta as displayed on the Ranger Vancouver Reliability Coordinator display.~~
 - ~~c. Verify if:~~
 - ~~Available NWPP reserve sharing to Alberta \geq Genesee SLC - Alberta CRO~~
 - ~~d. If **not**, then reduce Genesee SLC to:~~
 - ~~Genesee SLC = Available NWPP reserve sharing + Alberta CRO~~
 - ~~Pro-rata the Genesee SLC among the online Genesee generators based on STS levels as indicated in Table 7 (confidential).~~
 - ~~e. Issue directives to the Genesee and Keephills plant operators for the curtailments.~~
- ~~6. Determine from Table 5 the allowable Alberta-BC interconnection import ATC corresponding to the volume of the SLC at Genesee and:~~
 - ~~a. Re-post the Alberta-BC interconnection import ATC on the AESO website; enter the reason for change as "AIES transmission system constraints".~~
 - ~~b. Determine the Alberta-BC interconnection import TRM by:~~
 - ~~Import TRM = Import TTC (per OPP 304) - Import ATC~~

OPP 517 Keephills/Ellerslie/Genesee (KEG) Area Operation

- ~~e. Call and notify the BCTC Operator to change the Alberta-BC interconnection import TRM, TTC and ATC; confirm that these will be posted on the OASIS node immediately. Notify the BCTC Operator that Alberta is having a SLC greater than 450 MW.~~
- ~~d. Curtail current Alberta-BC import transactions to the allowable import ATC amount if required.~~
- ~~7. If 1203L was forced out of service, issue ancillary service directives to the dispatched supplemental and spinning reserves as required. Note that the reserves must be recovered within an hour.~~
- ~~8. Dispatch energy in the energy market merit order as required to maintain AIES supply and demand balance.~~
- ~~9. If the AIES experiences a supply shortfall, follow the procedures in OPP 801.~~
- ~~10. Initiate Operations callout (see OPP 1303) for unplanned security directives if not already done so in step 9.~~
- ~~11. Contact and notify the Vancouver Reliability Coordinator that the AIES is back within reliable operating limits when the required generation levels are achieved.~~
- ~~12. Coordinate the restoration of 1203L with the AltaLink and EPCOR Transmission Operators.~~
- ~~13. When 1203L has been restored:
 - ~~a. Cancel the directives for generation and reserve service curtailment to the Genesee and Keephills generators.~~
 - ~~b. Contact and notify the BCTC Operator to change the Alberta-BC interconnection import TRM, TTC and ATC as per OPP 304. Notify the BCTC Operator that Alberta is back to normal SLC level.~~
 - ~~c. Fax a written notification to BCTC for the TRM, TTC and ATC changes when time allows.~~
 - ~~d. Re-post the Alberta-BC interconnection import ATC, as per OPP 304, on the AESO website.~~
 - ~~e. Re-load Alberta-BC interconnection import transactions as appropriate.~~~~
- ~~14. Enter in the shift log (see OPP 1301) details of all security directives for generation and import curtailment and restoration including times, generator names and curtailment/restoration volumes.~~

5.5 1202L out of service

If 1202L is out of service, the SC will:

- ~~1. If 1202L was forced out of service, contact the AltaLink Transmission Operator to determine the status of 1202L.~~
- ~~2. If the outage to 1202L is anticipated to be more than 20 minutes, proceed with the curtailment procedure. Otherwise, maintain close communication with the AltaLink Transmission Operator to get update on the status of 1202L and re-evaluate the need to proceed with the curtailment procedure as required.~~
- ~~3. Contact and notify the Vancouver Reliability Coordinator that the AIES is experiencing abnormal operating conditions that could cause reliability concerns for the AIES.~~

Transmission

OPP 517 Keephills/Ellerslie/Genesee (KEG) Area Operation

- ~~4. Use the real time curtailment tool to determine the required curtailments to the area generators. Issue directives to the Genesee and Keephills plant operators for the curtailments.~~
- ~~5. If the real time curtailment tool is unavailable, use Table 6 to determine the curtailment requirements and issue directives to the Genesee and Keephills plant operators for the curtailments.~~
- ~~6. If 1202L was forced out of service, issue ancillary service directives to the dispatched supplemental and spinning reserves as required. Note that the reserves must be recovered within an hour.~~
- ~~7. Dispatch energy in the energy market merit order as required to maintain AIES supply and demand balance.~~
- ~~8. If the AIES experiences a supply shortfall, follow the procedures in OPP 801.~~
- ~~9. Initiate Operations callout (see OPP 1303) for unplanned security directives if not already done so in step 7.~~
- ~~10. Contact and notify the Vancouver Reliability Coordinator that the AIES is back within reliable operating limits when the required generation levels are achieved.~~
- ~~11. Coordinate the restoration of 1202L with the AltaLink Transmission Operators.~~
- ~~12. When 1202L has been restored, cancel the directives for generation and reserve service curtailment to the Genesee and Keephills generators.~~
- ~~13. Enter in the shift log (see OPP 1301) details of all security directives for generation and import curtailment and restoration including times, generator names and curtailment/ restoration volumes.~~

5.6 — 190L or 903L out of service

If 190L or 903L is out of service, the SC will:

- ~~1. If 190L or 903L was forced out of service, contact the AltaLink Transmission Operator to determine the status of the line.~~
- ~~2. If the outage is anticipated to last for more than 20 minutes, proceed with the curtailment procedure. Otherwise, maintain close communication with the AltaLink Transmission Operator to get update on the status of the line and re-evaluate the need to proceed with the curtailment procedure as required.~~
- ~~3. Use the real time curtailment tool to determine the required curtailments to the area generators. Issue directives to the Genesee and Keephills plant operators for the curtailments.~~
- ~~4. If the real time curtailment tool is unavailable, use Table 6 to determine the curtailment requirements and issue directives to the Genesee and Keephills plant operators for the curtailments.~~
- ~~5. If 190L or 903L was forced out of service, issue ancillary service directives to the dispatched supplemental and spinning reserves as required. Note that the reserves must be recovered within an hour.~~
- ~~6. Dispatch energy in the energy market merit order as required to maintain AIES supply and demand balance.~~
- ~~7. Initiate Operations callout (see OPP 1303) for unplanned security directives.~~

OPP 517 Keephills/Ellerslie/Genesee (KEG) Area Operation

- ~~8. Coordinate the restoration of 190L or 903L with the AltaLink Transmission Operator.~~
- ~~9. When 190L or 903L has been restored, cancel the directives for generation and reserve services curtailment to the Genesee and Keephills generators.~~
- ~~10. Enter in the shift log (see OPP 1301) details of all security directives for generation curtailment and restoration including times, generator names and curtailment/ restoration volumes.~~

5.7 ~~Keephills T320P Transformer # 1 out of service~~

~~If Keephills T320P T1 is out of service, the SC will:~~

- ~~1. If Keephills T320P T1 was forced out of service, contact the AltaLink Transmission Operator to determine the status of the transformer.~~
- ~~2. If the outage is anticipated to last for more than 20 minutes, proceed with the curtailment procedure. Otherwise, maintain close communication with the AltaLink Transmission Operator to get update on the status of the transformer and re-evaluate the need to proceed with the curtailment procedure as required.~~
- ~~3. Use the real time curtailment tool to determine the required curtailments to the area generators. Issue directives to the Genesee and Keephills plant operators for the curtailments.~~
- ~~4. If the real time curtailment tool is unavailable, use Table 6 to determine the curtailment requirements and issue directives to the Genesee and Keephills plant operators for the curtailments.~~
- ~~5. If Keephills T320P T1 was forced out of service, issue ancillary service directives to the dispatched supplemental and spinning reserves as required. Note that the reserves must be recovered within an hour.~~
- ~~6. Dispatch energy in the energy market merit order as required to maintain AIES supply and demand balance.~~
- ~~7. Initiate Operations callout (see OPP 1303) for unplanned security directives.~~
- ~~8. Coordinate the restoration of Keephills T320P T1 with the AltaLink Transmission Operator.~~
- ~~9. When Keephills T320P T1 has been restored, cancel the directives for generation and reserve services curtailment to the Genesee and Keephills generators.~~
- ~~10. Enter in the shift log (see OPP 1301) details of all security directives for generation curtailment and restoration including times, generator names and curtailment/ restoration volumes.~~

5.8 ~~After an SLC event at Genesee~~

~~After an SLC event at Genesee, the SC will:~~

- ~~1. Issue ASD for dispatched contingency reserves, if required.~~
- ~~2. If contingency reserve is required from the NWPP, request NWPP CRO for the amount equivalent to Genesee SLC minus the Alberta CRO. (refer to OPP 405 for details)~~
- ~~3. Arm IIRAS according to the import level on the Alberta-BC interconnection, including the NWPP reserve sharing energy (refer to OPP 312 for details).~~

Transmission

OPP 517 Keephills/Ellerslie/Genesee (KEG) Area Operation

- ~~4. Reduce the amount of the NWPP CRO request amount to zero, as energy is dispatched in the energy market.~~
- ~~5. Reduce the amount of the ASD to zero, as energy is dispatched in the energy market.~~
- ~~6. Adjust the Alberta-BC interconnection import TRM, TTC and ATC:
 - ~~a. Call and notify the BCTC Operator to change the Alberta-BC interconnection import TRM, TTC and ATC as per OPP 304. Notify the BCTC Operator that Alberta is back to its normal SLC level.~~
 - ~~b. Re-post the Alberta-BC interconnection import ATC, as per OPP 304, on the AESO website.~~
 - ~~c. Re-load Alberta-BC interconnection import transactions as appropriate.~~~~
- ~~7. Enter in the shift log (see OPP 1301) details of the event and Northwest Power Pool reserve sharing request.~~

5.9 Managing voltage when 1209L or 1202L is out of service

When 1209L or 1202L is out of service, the SC will:

- ~~1. Monitor the 240 kV bus voltages at the Ellerslie substation (F89S) and the East Edmonton substation (F39S) which must be maintained above 246 kV and 244 kV respectively.~~
- ~~2. If the 240 kV bus voltages are below the above specified voltage levels, follow the following steps, as far as practical, to maintain the voltages:
 - ~~a. Switch on all capacitor banks in the Edmonton and the Fort Saskatchewan area.~~
 - ~~b. Coordinate with Keephills plant operator to raise the 240 kV bus at the Keephills substation T320P to the higher end of the desired range as specified in OPP 702.~~
 - ~~c. Coordinate with Genesee plant operator to raise the 500 kV bus at Genesee substation E330P to the higher end of the desired range as specified in OPP 702.~~
 - ~~d. Direct more generation in the Edmonton area and the Fort Saskatchewan area.~~
 - ~~e. Perform a real time study to determine other possible mitigation measures including shedding load in Edmonton area.~~~~

6. ~~Figures and Tables~~

Figure 1

KEG area transmission system

Transmission

OPP 517 Keephills/Ellerslie/Genesee (KEG) Area Operation

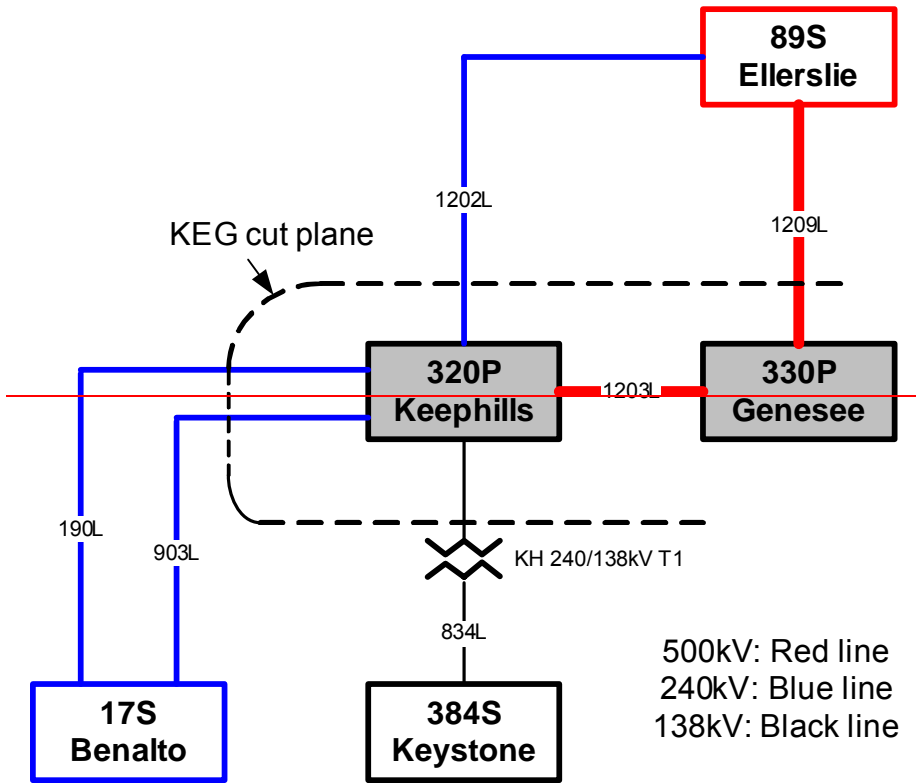
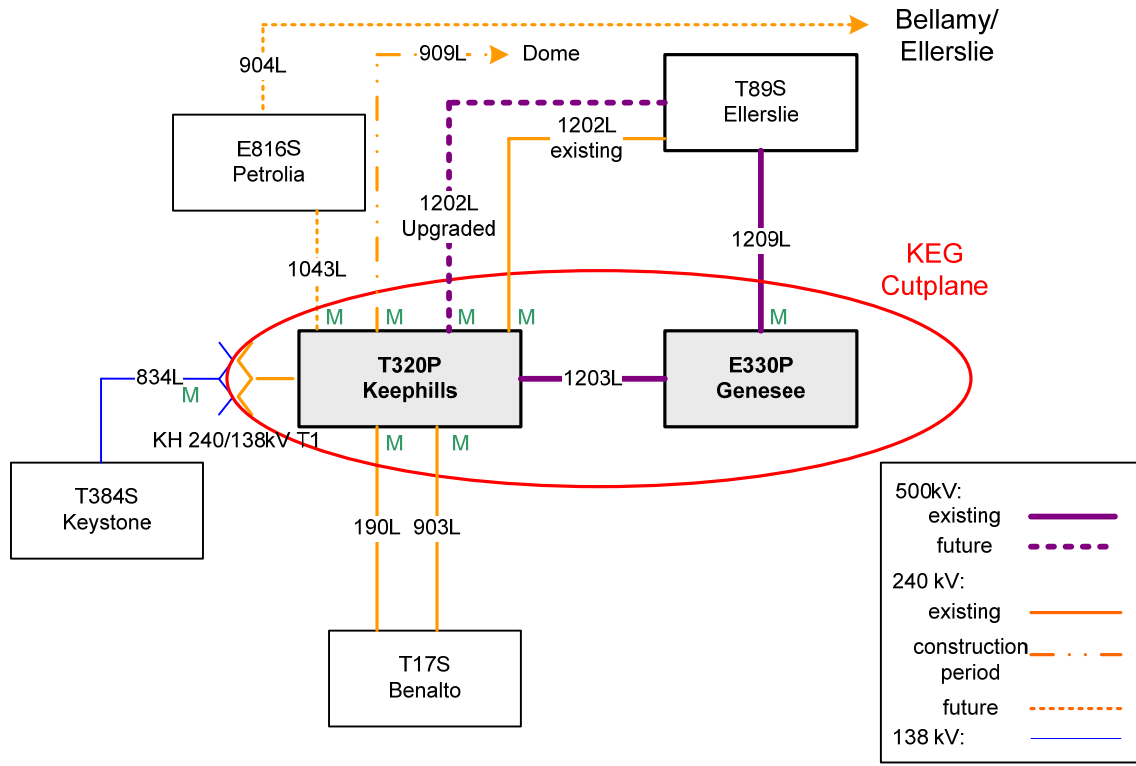

Transmission

OPP 517 Keephills/Ellerslie/Genesee (KEG) Area Operation

Table 1

Edmonton area load is greater than or equal to 1,850 MW

Clover Bar #1	Clover Bar #2	KEG Cut Plane Limit (MW)
on line	on line	Not applicable
off line	off line	1,840 [†]
on line	off line	1,880 [†]
off line	on line	Not applicable

Note:

—1. This is a voltage stability limit. When it is exceeded, curtail total net generation and dispatched operating reserves from the Genesee and Keephills plants on a pro-rata basis.

Table 2

Edmonton area load is greater than or equal to 1,850 MW and any two units of Sundance #1, #2, #3, #4, #5 and #6 are off line.

Clover Bar #1	Clover Bar #2	KEG Cut Plane Limit (MW)
on line	on line	Not applicable
off line	off line	1,880 [†]
on line	off line	1,880 [†]
off line	on line	1,920 [†]

Note:

—1. This is a voltage stability limit. When it is exceeded, curtail total net generation and dispatched operating reserves from the Genesee and Keephills plants on a pro-rata basis.

Table 3

Remedial actions due to KEG area N-1 contingencies

N-1 Contingencies	Remedial Actions
1209L (Genesee E330P— Ellerslie T89S) out of service	<p>—1. Limit the KEG cut plane flow to 1,240 MW and 1,300 MW in summer and winter respectively by curtailing total net generation and dispatched operating reserves from the Genesee and Keephills plants on a pro-rata basis.</p> <p>—2. Invoke SLC procedures:</p> <ul style="list-style-type: none"> • If AB-BC import transfer limit is not constrained, curtail the import such that the sum of Alberta-BC interconnection import and the SLC Genesee is not greater than 1,000 MW. Next, curtail the total net generation and dispatched operating reserves from the Genesee plant, if required. • If AB-BC import transfer limit is constrained due to transmission element outages per OPP 304, curtail total net generation and dispatched operating reserves from the Genesee plant to 450 MW.

Transmission

OPP 517 Keephills/Ellerslie/Genesee (KEG) Area Operation

N-1 Contingencies	Remedial Actions
1203L (Keephills T320P— Genesee E330P) out of service	Invoke SLC procedures: <ul style="list-style-type: none"> •If AB-BC import transfer limit is not constrained, curtail the import such that the sum of Alberta-BC interconnection import and the SLC Genesee is not greater than 1,000 MW. Next, curtail the total net generation and dispatched operating reserves from the Genesee plant, if required. •If AB-BC import transfer limit is constrained due to transmission element outages per OPP 304, curtail total net generation and dispatched operating reserves from the Genesee plant to 450 MW.
1202L (Keephills T320P— Ellerslie T89S) out of service	<ul style="list-style-type: none"> •Limit the KEG cut plane flow to 1,240 MW and 1,300 MW in summer and winter respectively by curtailing total net generation and dispatched operating reserves from the Genesee and Keephills plants on a pro-rata basis.
190L (Keephills T320P— Benalto T17S) out of service	<ul style="list-style-type: none"> •Limit the KEG cut plane flow to 1,620 MW in summer and 1,750 MW by curtailing total net generation and dispatched operating reserves from the Genesee and Keephills plants on a pro-rata basis •Limit the KEG cut plane flow to 1,500 MW by curtailing total net generation and dispatched operating reserves from the Genesee and Keephills plants on a pro-rata basis if KH1 or KH2 is offline
903L (Keephills T320P— Benalto T17S) out of service	<ul style="list-style-type: none"> •Limit the KEG cut plane flow to 1,660 MW in summer and 1,750 MW in winter respectively by curtailing total net generation and dispatched operating reserves from the Genesee and Keephills plants on a pro-rata basis •Limit the KEG cut plane flow to 1,500 MW by curtailing total net generation and dispatched operating reserves from the Genesee and Keephills plants on a pro-rata basis, if KH1 or KH2 is offline
Keephills T320P-T1 out of service	<ul style="list-style-type: none"> •Limit the KEG cut plane flow to 1,910 MW by curtailing total net generation and dispatched operating reserves from the Genesee and Keephills plants on a pro-rata basis.

Table 4

Maximum allowable most severe single contingency ~~single largest contingency (SLC)~~ at Genesee when 1203L or 1209L is out of service

System Conditions	Maximum Allowable SLC at Genesee (MW)
Alberta-BC Interconnection import TTC not constrained by transmission element outages as identified in Table 3 of OPP 304	1,000 (zero import assumed)
Alberta-BC Interconnection import TTC constrained by transmission element outages as identified in Table 3 of OPP 304	450

Table 2

Alberta-BC interconnection import ATC for various Genesee most severe single contingency, (identified as MSSC in the table below) levels when 1203L or 1209L is out of service

<u>Genesee MSSC (MW)¹</u>	<u>Alberta-BC Interconnection Import ATC (MW)</u>

Transmission

OPP 517 Keephills/Ellerslie/Genesee (KEG) Area Operation

<u>Genesee MSSC ≤450 MW</u>	<u>As per OPP 304 Table 3 and without the 1203L or 1209L constraint</u>
<u>450 MW < Genesee MSSC < 1,000 MW</u>	<u>1,000 MW minus Genesee MSSC</u>
<u>1,000 MW ≤ Genesee MSSC</u>	<u>0</u>

Note:

1. Genesee MSSC is the sum of the total net generation and dispatched operating reserves of the generating units at Genesee.

Table 3

KEG area generators contracted STS levels

Confidential

Table 4

KEG area generators minimum stable generation levels

Confidential

~~—View confidential Table 3 and Table 4 Table 5~~

~~—Alberta-BC interconnection import ATC for various Genesee SLC levels when 1203L or 1209L is out of service~~

—Genesee SLC (MW)[†]	—Alberta-BC Interconnection Import ATC (MW)
—	—
—Genesee SLC ≤450 MW	—As per OPP 304 Table and without the 1203L or 1209L constraint
—450 MW < Genesee SLC < 1,000 MW	—1,000 MW minus Genesee SLC
—1,000 MW ≤ Genesee SLC	—0

~~—Note:~~

~~—1. Genesee SLC is the sum of the total net generation and dispatched operating reserves of the generating units at Genesee.~~

~~—~~

Table 6

~~KEG area generator directive levels after certain area 240 kV line contingencies when the real time curtailment tool is unavailable.~~

~~Legend:~~

~~(S) indicates summer, from May 1 until October 31~~

~~(W) indicates winter, from November 1 until April 30~~

~~A. After a 1209L contingency and Alberta-BC import is not constrained~~

KEG Generator Status	Directive Level (MW)[†]					AB-BC Import
	KH 1	KH 2	GEN 1	GEN 2	GEN 3	
All KEG area generators on-line	239 (S) 251 (W)	239 (S) 251 (W)	239 (S) 251 (W)	239 (S) 251 (W)	284 (S) 296 (W)	TTC per OPP 304 ATC = 238 (S) or 202 (W) TRM = TTC - ATC
Genesee 3 off-line	310 (S)	310 (S)	310 (S)	310 (S)	n/a	TTC per OPP 304

Transmission

OPP 517 Keephills/Ellerslie/Genesee (KEG) Area Operation

	325 (W)	325 (W)	325 (W)	325 (W)		ATC = 380 (S) or 350 (W) TRM = TTC - ATC
Genesee 1 or Genesee 2 off line	297 (S) 311 (W)	297 (S) 311 (W)	0 or 297 (S) 0 or 311 (W)	0 or 297 (S) 0 or 311 (W)	349 (S) 367 (W)	TTC per OPP 304 ATC = 354 (S) or 322 (W) TRM = TTC - ATC
Keephills 1 or Keephills 2 off line	0 or 297 (S) 0 or 311 (W)	0 or 297 (S) 0 or 311 (W)	297 (S) 311 (W)	297 (S) 311 (W)	349 (S) 367 (W)	TTC per OPP 304 ATC = 57 (S) or 11 (W) TRM = TTC - ATC

Note:

~~1. Directive level is for the sum of net generation output plus dispatched reserve services.~~

Transmission

OPP 517 Keephills/Ellerslie/Genesee (KEG) Area Operation

~~B. After a 1209L contingency and Alberta-BC import is constrained~~

KEG Generator Status	Directive Level (MW)¹					AB-BC Import
	KH-1	KH-2	GEN-1	GEN-2	GEN-3	
All KEG-area generators on-line	383	383	142	142	166	As per OPP-304
Genesee-3 off-line	383	383	225	225	n/a	As per OPP-304
Genesee-1 or Genesee-2 off-line	383	383	0 or 207	0 or 207	243	As per OPP-304
Keephills-1 or Keephills-2 off-line	0 or 383	0 or 383	142	142	166	As per OPP-304

~~Note:~~

~~—1. Directive level is for the sum of net generation output plus dispatched reserve services.~~

~~C. After a 1203L contingency and Alberta-BC import is not constrained~~

KEG Generator Status	Directive Level (MW)¹					AB-BC Import
	KH-1	KH-2	GEN-1	GEN-2	GEN-3	
All KEG-area generators on-line	n/a	n/a	314	314	372	TTC per OPP-304 ATC = 0 TRM = TTC - ATC
Genesee-3 off-line	n/a	n/a	381	381	n/a	TTC per OPP-304 ATC = 238 TRM = TTC - ATC
Genesee-1 or Genesee-2 off-line	n/a	n/a	0 or 381	0 or 381	450	TTC per OPP-304 ATC = 167 TRM = TTC - ATC

~~Note:~~

~~—1. Directive level is for the sum of net generation output plus dispatched reserve services.~~

~~D. After a 1203L contingency and Alberta-BC import is constrained~~

KEG Generator Status	Directive Level (MW)¹					AB-BC Import
	KH-1	KH-2	GEN-1	GEN-2	GEN-3	
All KEG-area generators on-line	n/a	n/a	141	141	168	As per OPP-304
Genesee-3 off-line	n/a	n/a	225	225	n/a	As per OPP-304
Genesee-1 or Genesee-2 off-line	n/a	n/a	0 or 207	0 or 207	243	As per OPP-304

~~Note:~~

~~—1. Directive level is for the sum of net generation output plus dispatched reserve services.~~

Transmission

OPP 517 Keephills/Ellerslie/Genesee (KEG) Area Operation

E. After a 1202L contingency

KEG Generator Status	Directive Level (MW) [†]				
	KH-1	KH-2	GEN-1	GEN-2	GEN-3
All KEG-area generators on-line	239 (S) 251 (W)	239 (S) 251 (W)	239 (S) 251 (W)	239 (S) 251 (W)	239 (S) 296 (W)
Genesee 3 off line	310 (S) 325 (W)	310 (S) 325 (W)	310 (S) 325 (W)	310 (S) 325 (W)	n/a
Genesee 1 or Genesee 2 off line	297 (S) 311 (W)	297 (S) 311 (W)	0 or 297 (S) 0 or 311 (W)	0 or 297 (S) 0 or 311 (W)	349 (S) or 367 (W)
Keephills 1 or Keephills 2 off line	0 or 297 (S) 0 or 311 (W)	0 or 297 (S) 0 or 311 (W)	297 (S) 311 (W)	297 (S) 311 (W)	349 (S) 367 (W)

Note:

—1. Directive level is for the sum of net generation output *plus* dispatched reserve services.

F. After a 190L contingency

KEG Generator Status	Directive Level (MW) [†]				
	KH-1	KH-2	GEN-1	GEN-2	GEN-3
All KEG-area generators on-line	313 (S) 338 (W)	313 (S) 338 (W)	313 (S) 338 (W)	313 (S) 338 (W)	368 (S) 398 (W)
Genesee 3 off line	381	381	381	381	n/a
Genesee 1 or Genesee 2 off line	381	381	0 or 381	0 or 381	450
Keephills 1 or Keephills 2 off line	0 or 359	0 or 359	359	359	423

Note:

—1. Directive level is for the sum of net generation output *plus* dispatched reserve services.

G. After a 903L contingency

KEG Generator Status	Directive Level (MW) [†]				
	KH-1	KH-2	GEN-1	GEN-2	GEN-3
All KEG-area generators on-line	320 (S) 338 (W)	320 (S) 338 (W)	320 (S) 338 (W)	320 (S) 338 (W)	380 (S) 398 (W)
Genesee 3 off line	381	381	381	381	n/a
Genesee 1 or Genesee 2 off line	381	381	0 or 381	0 or 381	450
Keephills 1 or Keephills 2 off line	0 or 359	0 or 359	359	359	423

Note:

—1. Directive level is for the sum of net generation output *plus* dispatched reserve services.

Transmission

OPP 517 Keephills/Ellerslie/Genesee (KEG) Area Operation

H. After a Keephills T320P T1 contingency

KEG Generators status	Directive levels (MW)¹				
	KH-1	KH-2	GEN-1	GEN-2	GEN-3
All KEG-area generators on-line	369	369	369	369	434
Genesee-3 off-line	383	383	381	381	n/a
Genesee-1 or Genesee-2 off-line	383	383	0 or 381	0 or 381	450
Keephills-1 or Keephills-2 off-line	0 or 383	0 or 383	381	381	450

Note:

~~1. Directive level is for the sum of net generation output plus dispatched reserve services.~~

~~—~~

OPP 517 Keephills/Ellerslie/Genesee (KEG) Area Operation

Table 7

~~KEG area generators contracted STS levels~~

~~Confidential~~

Table 8

~~KEG area generators minimum stable generation levels~~

—

7. Revision History

Issued	Description
2010-xx-xx	Supersedes 2008-11-27
2008-11-27	Supersedes interim OPP effective 2008-11-01
2008-11-01	Approved for interim implementation effective 2008-11-01
2008-05-30	Approved for interim implementation effective 2008-05-30
2007-09-27	Supersedes 2006-07-11
2006-07-11	Supersedes 2005-03-30
2005-03-30	Supersedes interim OPP effective 2004-11-02
2004-11-02	New issue approved for interim implementation

8. SC Tool Version

Date	Version	Description
2010-05-27	SC Workbook	1st stage of Keephills 3 project.
2008-11-01	MARGO release 4.1	Implement the KEG cut plane
2008-05-30	MARGO release 3.2.1.1	Implement changes for 500 kV upgrade